

## 1. Introduction

### 1.1 Product overview

The **USB 3.0 Ethernet Adapter** allows your computer instantly connect to a 10/100/1000Mbps network through simply a USB port; no hassle to open up your computer case as is required for an internal card now! It's also an ideal USB to LAN alternative for gaming console that needs network access in an environment lacking wireless capability.

Compared with USB 1.1 standard which offers 12 Mbps speed, and USB 2.0 standard which offers 480Mbps , the adapter's compliance with USB 3.0 (600Mbps) ensures true 10/100/1000 Mbps network speed without any compromise. Furthermore, the adapter is compact and is USB bus-powered; it requires no external power adapter, so that you can use it without crowding your workspace at all.

### 1.2 Appearance



### 1.3 Application Diagram

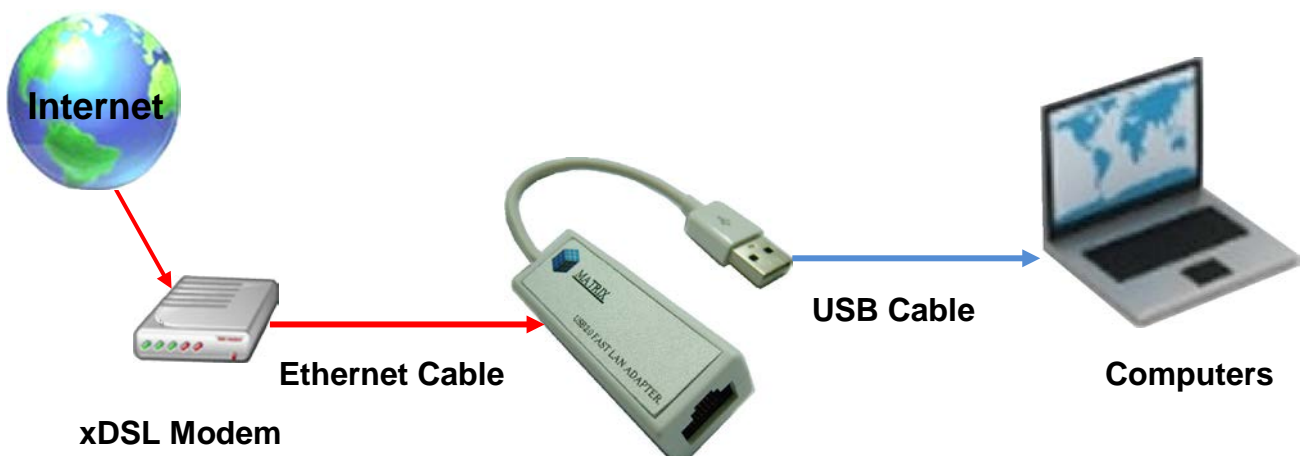

## 1.4 MATRIX P/N

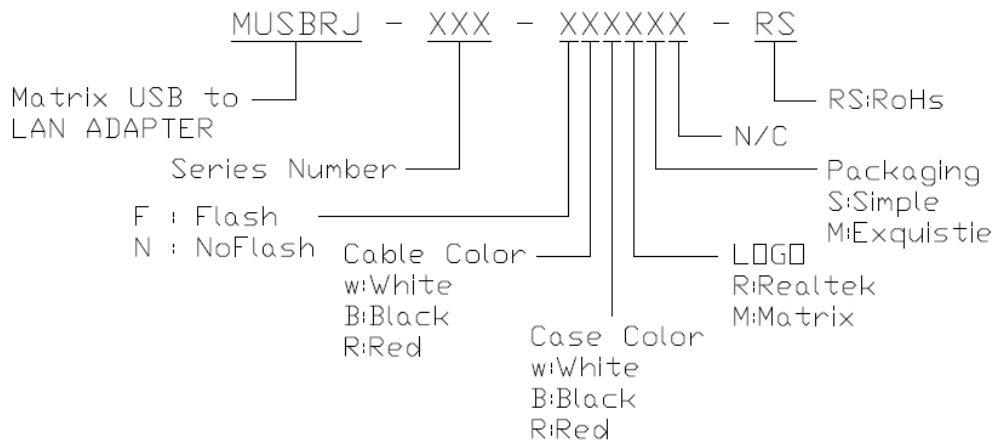

## 2 Hardware and software specification

### 2.1 Hardware Specification

- 2.1.1 Integrated 10/100/1000M transceiver
- 2.1.2 Auto-Negotiation with Next Page capability
- 2.1.3 Supports USB 3.0 , 2.0 and 1.1
- 2.1.4 Supports CDC-ECM
- 2.1.5 Supports LPM (Link Power Management)
- 2.1.6 Crossover Detection & Auto-Correction
- 2.1.7 Supports Wake-On-LAN and 'RealWoW!' (Wake-On-WAN) Technology (see note 1)
- 2.1.8 Supports ECMA-393 ECMA ProxZzzy Standard for sleeping hosts (see note 1)
- 2.1.9 XTAL-Less Wake-On-LAN
- 2.1.10 Supports power down/link down power saving
- 2.1.11 Transmit/Receive on-chip buffer support
- 2.1.12 Embedded OTP memory can replace external EEPROM
- 2.1.13 Built-in switching regulator and LDO regulator
- 2.1.14 Supports hardware CRC (Cyclic Redundancy Check) function
- 2.1.15 LAN disable with GPIO pin
- 2.1.16 SPI Flash Interface

### 2.2 Software Specification

2.2.1 Microsoft NDIS5, NDIS6 Checksum Offload (IPv4, IPv6, TCP, UDP) and Segmentation Task-offload (Large send v1 and Large send v2) support

2.2.2 Supports jumbo frame to 9K bytes

### 2.3 IEEE

2.3.1 Supports Full Duplex flow control (IEEE 802.3x)

2.3.2 Fully compliant with IEEE 802.3, IEEE 802.3u

2.3.3 Supports IEEE 802.1P Layer 2 Priority Encoding

2.3.4 Supports IEEE 802.1Q VLAN tagging

2.3.5 Supports IEEE 802.3az-2010 (EEE)

### 2.4 Intel CPPM (Converged Platform Power Management)

2.4.1 Supports L1 with 3ms BESL (USB 2.0)

2.4.2 Dynamic LTM messaging (USB 3.0)

2.4.3 Supports U1/U2 (USB3.0)

2.4.4 Supports selective suspend

**Note 1. Select between Real WoW! or ECMA, only one feature can be active at a time**

## 3 Mechanical Specification

### 3.1 Product Mechanical outline Specification

- Color: White , Black , Red
- Material: Plastic

#### 3.1.1 Mechanical Drawing

