



**Feature**



- Designed to Support 10GBASE-T Transceivers
- Non-PoE product.
- Compliant with IEEE 802.3 standard
- OCL:200uH min @100KHz,100mV
- LL:0.35uH max @200KHz,100mV
- CWW:30pF max @200KHz,1V
- DCR(pri): 0.5Ω max,DCR(sec):0.9Ω max
- Low profile package for PCI Express
- RoHS compliance and peak reflow temperature rating 260°C
- Operating Temperature 0°C to 70°C
- Storage temperature -25°C to +125°C.

**Electrical Specifications@25°C**

Part Number	Insertion Loss (dB Max)	Return Loss (dB Min)@Load 100Ω					DCMR (dB Min)			Cross talk Attenuation (dBMin)					HI-POT (Vrms)
		0.1~500MHz	1-10MHz	100MHz	300MHz	400MHz	500MHz	1-125MHz	250MHz	500MHz	1MHz	10MHz	100MHz	400MHz	
ML24S16RS	-3	-16	-14	-10	-10	-10	-30	-30	-20	-65	-42	-37	-30	-30	1500

**Schematic**

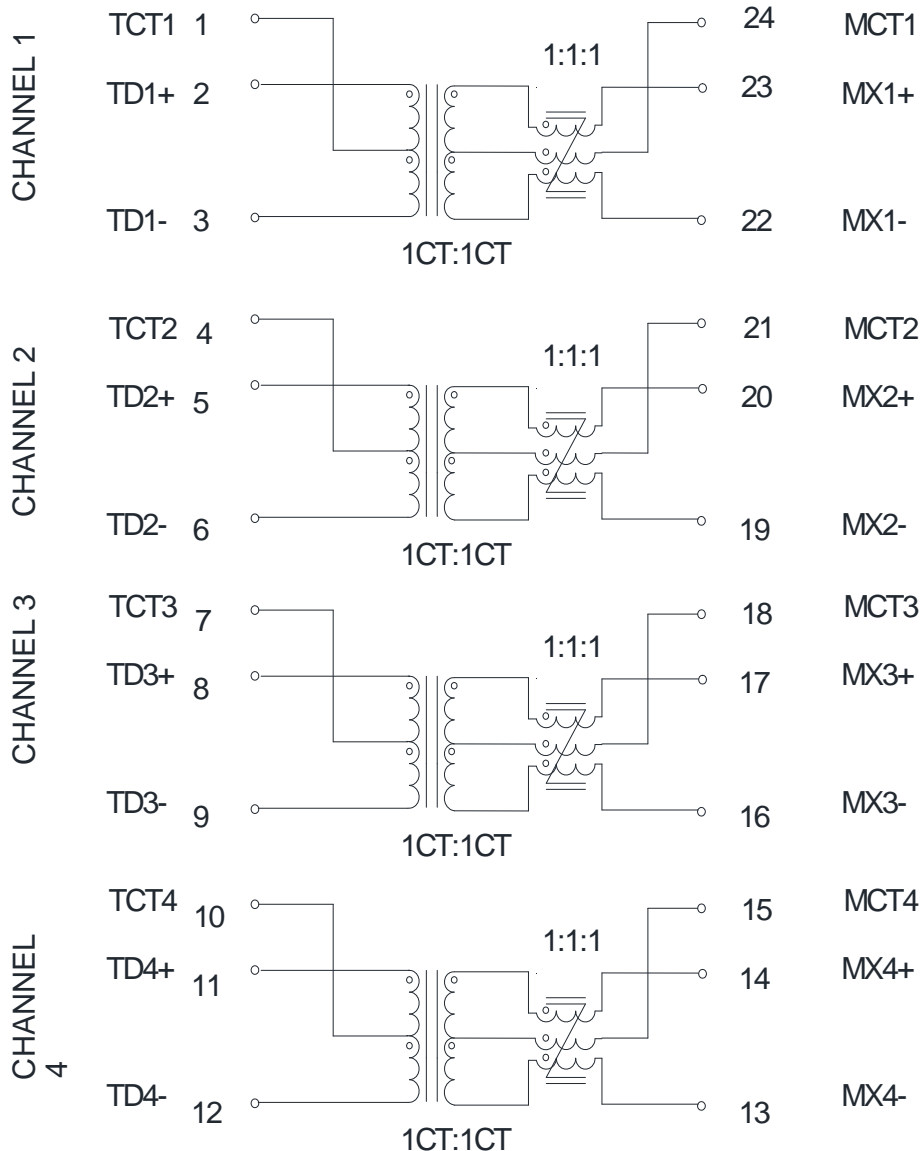



Mechanical

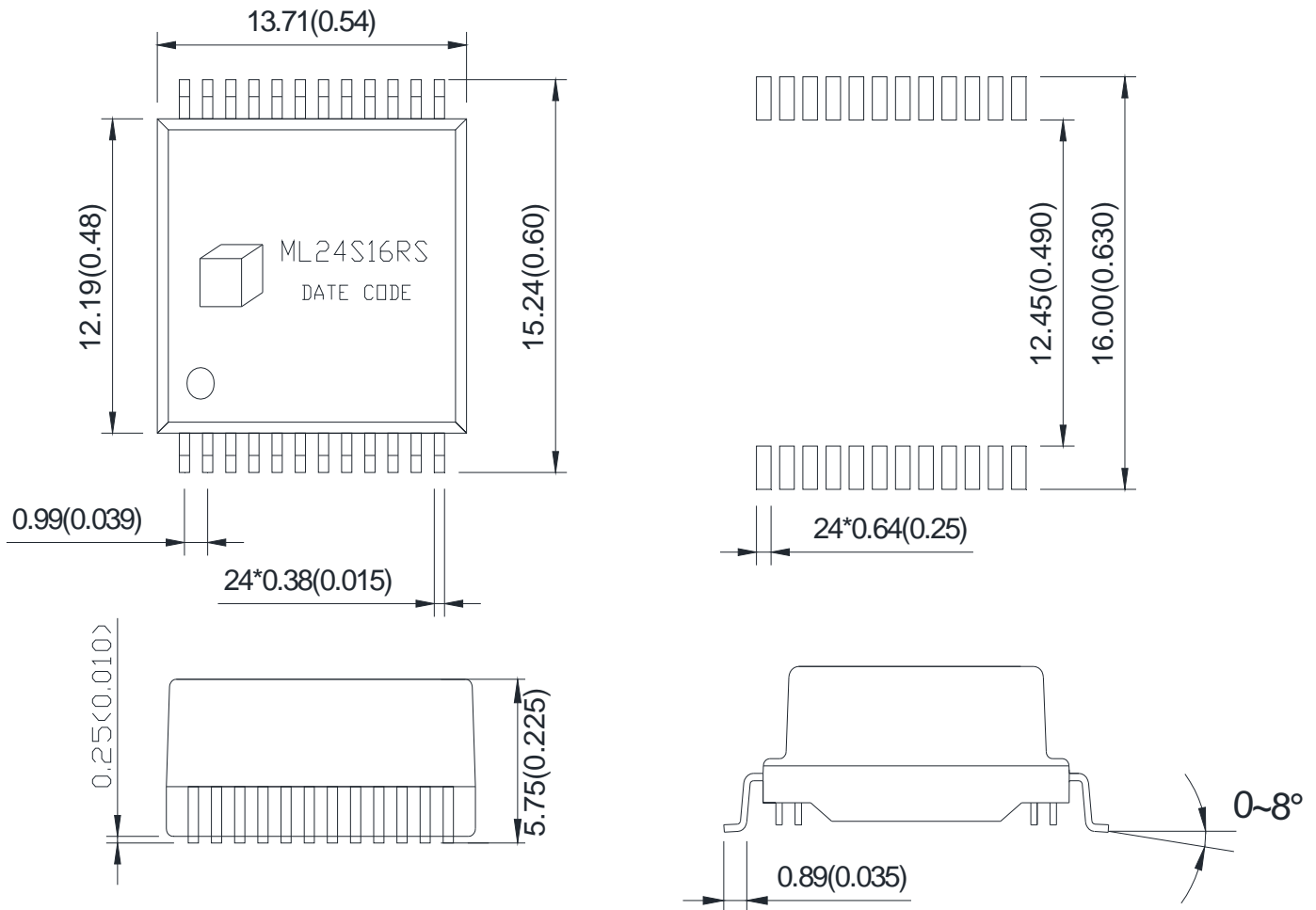

Dimension:mm(inch)

Unless otherwise specified , all tolerance are +/-0.25(0.01)