

# GP Component

REV.	ECN NO.	LOCATIONS	DESCRIPTION	DATE	DESIGN
A0			Initial	2017/03/28	Phebe Su

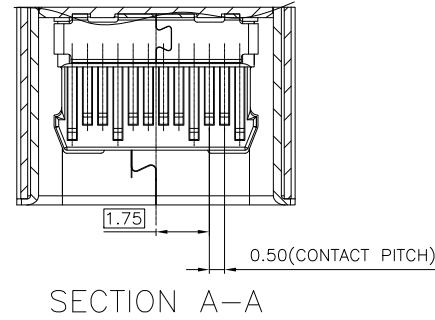
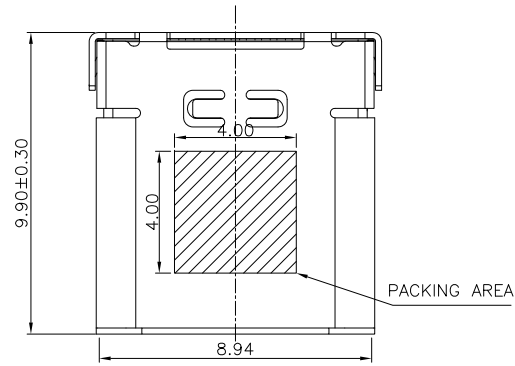

### NOTES:

- MATERIAL:**  
 MOLDING: LCP BLACK UL94V-0  
 CONTACT: COPPER ALLOY.  
 GOLD FLASH ON CONTACT AREA, 100u"  
 Min TIN (LEAD FREE) ON SOLDER AREA,  
 SHELL: SUS304-H,T=0.30±0.03mm  
 50u" NICKEL PLATING OVER ALL.  
 SHILD: SUS304-H,T=0.12±0.03mm
- MECHANICAL:**  
 INSERTION: 5~20N.  
 EXTRACTION: 8~20N.  
 DURABILITY: 10000 CYCLES
- ELECTRICAL:**  
 CURRENT: 5A MIN FOR VBUS;  
 0.25A MIN FOR OTHER.  
 VOLTAGE: 20 V MAX  
 WITHSTANDING VOLTAGE: 100V AC.  
 CONTACT RESISTANCE: 40mΩ MAX.  
 INSULATION RESISTANCE: 100MΩ MIN.
- ENVIRONMENTAL**  
 TEMPERATURE RANGE -55°C ~ +85°C

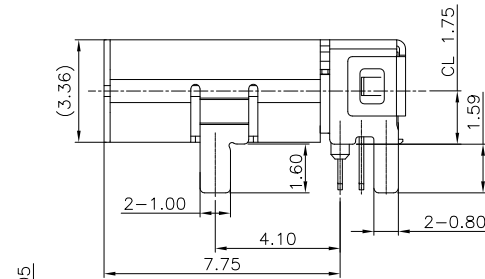
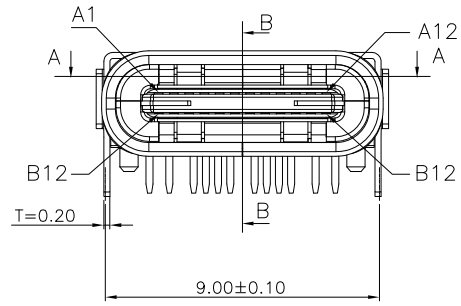

MATRIX PART NO:

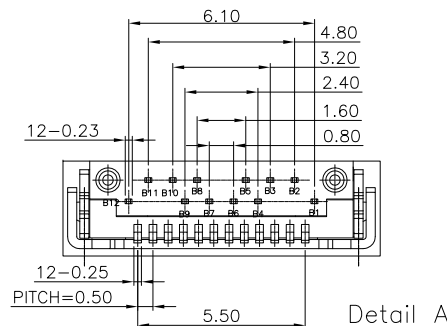
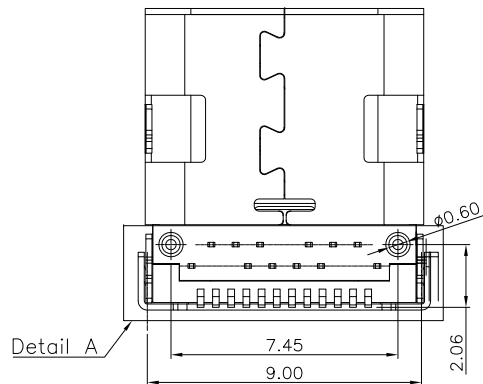
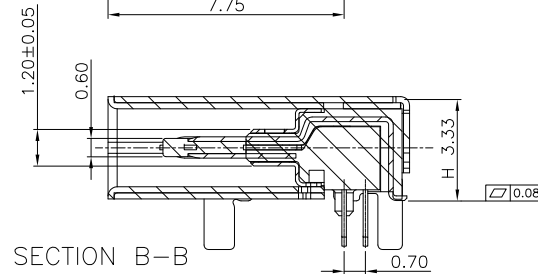
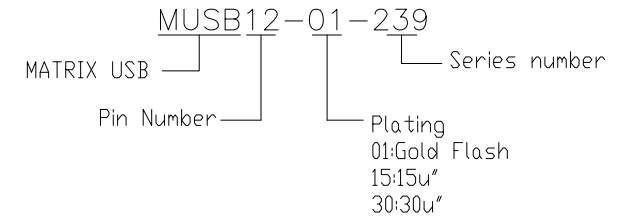

Matrix Electronics Co.,Ltd			
<b>TOLERANCE:</b> X:X ±0.38 X:XX ±0.25 X:XXX ±0.10 ANGLE: ±3°	<b>DESIGN BY :</b> Phebe Su	<b>DATE :</b> 2017/03/28	<b>PART NAME:</b> USB 3.1 Type C Gen 2 Female R/A, CL 1.75
<b>UNIT: mm [inch]</b>	<b>CHECKED BY:</b> Vicky Hsieh	<b>DATE :</b> 2017/03/28	<b>PART NO.</b> MUSB12-01-239
<b>SCALE:1:1</b> <b>SIZE:A4</b>	<b>APPROVED BY1:</b> Richard Hsieh	<b>DATE :</b> 2017/03/28	<b>MOLD NO.</b> NA
	<b>APPROVED BY2:</b> Richard Hsieh	<b>DATE :</b> 2017/03/28	<b>DRAW NO.</b>
			<b>SHEET NO.</b> 1 OF 2

# GP Component

REV.	ECN NO.	LOCATIONS	DESCRIPTION	DATE	DESIGN
A0			Initial	2017/03/28	Phebe Su

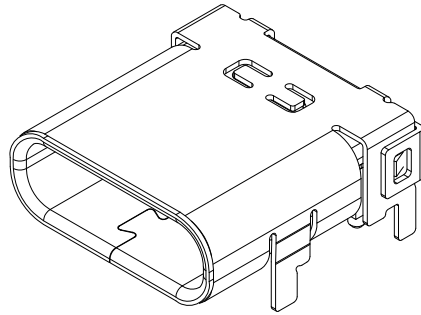

## USB TYPE-C FULL-FEATURED RECEPTACLE INTERFACE PIN ASSIGNMENTS

PIN	Signal Name	Description	PIN	Signal Name	Description
A1	GND	Ground return	B12	GND	Ground return
A2	SSTXp1	Positive half of first SuperSpeed TX differential pair	B11	SSRXp1	Positive half of first SuperSpeed RX differential pair
A3	SSTXn1	Negative half of first SuperSpeed TX differential pair	B10	SSRXn1	Negative half of first SuperSpeed RX differential pair
A4	VBUS	Bus Power	B9	VBUS	Bus Power
A5	CC1	Configuration Channel	B8	SBU2	Sideband Use (SBU)
A6	Dp1	Positive half of the USB 2.0 differential pair-Position 1	B7	Dn2	Negative half of the USB 2.0 differential pair-Position 2
A7	Dn1	Negative half of the USB 2.0 differential pair-Position 1	B6	Dp2	Positive half of the USB 2.0 differential pair-Position 2
A8	SBU1	Sideband Use (SBU)	B5	CC2	Configuraation Channel
A9	VBUS	Bus Power	B4	VBUS	Bus Power
A10	SSRXn2	Negative half of second SuperSpeed RX differential pair	B3	SSTXn2	Negative half of second SuperSpeed TX differential pair
A11	SSRXp2	Positive half of second SuperSpeed RX differential pair	B2	SSTXp2	Positive half of second SuperSpeed TX differential pair
A12	GND	Ground return	B1	GND	Ground return

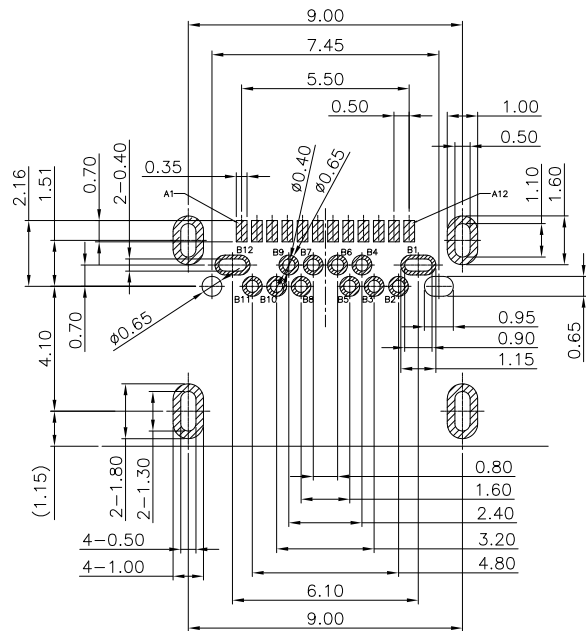

RECOMMEND P.C.B LAYOUT (COMPONENT SIDE)

TOLERANCE FOR PCB LAYOUT IS  $\pm 0.05$

KEEP OUT AREA

NO	VARIETY	QTY	METERIAL	REMARK
<b>TOLERANCE:</b> X.X $\pm 0.38$ X.XX $\pm 0.25$ X.XXX $\pm 0.10$ ANGLE: $\pm 3^\circ$		<b>DESIGN BY :</b> Phebe Su		<b>DATE :</b> 2017/03/28
		<b>CHECKED BY:</b> Vicky Hsieh		<b>DATE :</b> 2017/03/28
		<b>APPROVED BY1:</b> Richard Hsieh		<b>DATE :</b> 2017/03/28
		<b>APPROVED BY2:</b> Richard Hsieh		<b>DATE :</b> 2017/03/28
			<b>PART NAME:</b> USB 3.1 Type C Gen 2 Female R/A, CL 1.75	<b>PART NO.</b> MUSB12-01-239
			<b>MOLD NO.</b> NA	
			<b>DRAW NO.</b>	
			<b>SHEET NO.</b> 2 OF 2	